

**SECTION: A**

1. Which country neighbours Uganda to the south west?

.....  
.....

2. Give one-way highlands hinder economic development of an area.

.....  
.....

3. How can tourists be a threat to a host country?

.....  
.....

4. State any one way of preserving culture in our district.

.....  
.....

5. How do newspapers promote trade?

.....  
.....

6. In which way does a constitution promote human rights?

.....  
.....

7. Name the official who killed Fierce Lions in Kenya during the construction of Uganda railway.

.....  
.....

8. How does climate influence people's way of dressing?

.....  
.....

9. Give any one-way trees survive desert condition in desert areas?

.....  
.....

10. Which was the first group of Europeans to come to East Africa?

.....  
.....

11. To which ministry does the Uganda Electoral Commission Belong?

.....  
.....

12. Mention any one way of controlling global warming.

.....  
.....

13. Give the meaning of the term population explosion.

.....  
.....

14. Apart from soda ash, mention any other mineral mined from lake Magadi.

.....  
.....

15. State one way in which trees control landslides in mountainous areas.

.....  
.....

16. How is Kampala city important to the member countries of EAC?

.....  
.....

17. What does the baby on the independence monument of Uganda symbolize?

.....

**18.** Give one way Pan Africanists spread their messages to other Africans.

.....  
.....

**19.** State any one cause of conflicts between a school and community.

.....  
.....

**20.** In the space below, draw a road sign for humps a head.

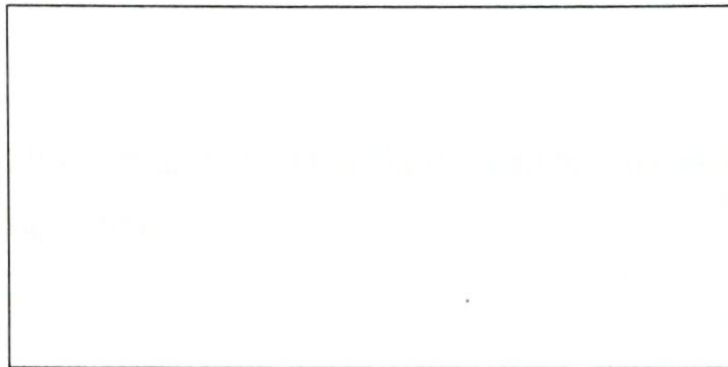

**21.** Which political party led Uganda to internal self-governance?

.....  
.....

**22.** Give one way the extraction of crude oil from Albertine will affect the people in that region.

.....  
.....

**23.** How did Dr. David Livingstone help in stopping slave trade in central and East Africa.

.....  
.....

**24.** Mention any one artificial source of crafts.

.....

**25. How can crop farming be made possible in drier areas of Uganda?**

.....  
.....

**26. In which way does altitude influence vegetation distribution?**

.....  
.....

**27. Write UCC in full.**

.....  
.....

**28. How did the occupation of the Bantu lead to their settlements in areas they occupy today?**

.....  
.....

**29. Name the narrow water channel that connects Africa to Europe.**

.....

**30. Give one-way colonialists used to establish colonial rule in Uganda.**

.....  
.....

**31. How was early man able to trap fast running animals?**

.....  
.....

**32. Give the importance of hills to telecommunication companies.**

.....  
.....

**33. What title is given to the political head of a sub-county?**

.....  
.....

**34.** State any one way one can lose his/her citizenship in Uganda.

.....  
.....

**35.** How is the water hyacinth a problem to the fishing industry?

.....  
.....

For questions 36 – 40, answer Either Christianity OR Islam But not both in the same number.

**36.** Either:

What was the work of the first apostles before Jesus Christ called them?

.....  
.....

OR:

What was the work of the Prophet Muhammed before Allah called him?

.....  
.....

**37.** Either:

How did Prophet John the Baptist meet his death?

.....  
.....

OR:

Who was the first Moslem Martyr?

.....  
.....

**38. Either:**

What general name was given to the Ten Commandments?

.....  
.....

**OR:**

Give the meaning of the term Haddith.

.....  
.....

**39. For both:**

Give any one-way people of ATR reconciled with one another.

.....  
.....

**40. Either:**

Mention any one-way Christians show respect to God during prayers.

.....  
.....

**OR:**

Mention any one way Muslims show respect to Allah during prayers.

.....  
.....

**SECTION: B**

**41. a) In which season does Mediterranean climatic region receive rainfall?**

.....  
.....

**b) How do prevailing winds influence the climate of an area?**

.....  
.....

c) Mention the major economic activity done in Mediterranean climatic region.

.....  
.....

d) State any one way people can modify the climate of an area.

.....  
.....

**42.** a) State any one social contribution of the Bachwezi in East Africa?

.....  
.....

b) Why did the Bachwezi dig ditches near their homes?

.....  
.....

c) Where were the headquarters of the Chwezi Empire?

.....  
.....

d) How did the coming of the Lou affect the Chwezi Empire?

.....  
.....

**43.** a) How is decentralization policy in Uganda implemented?

.....  
.....

b) Give any one way people benefit from decentralization policy.

(i) .....

(ii) .....

c) Mention one problem the government faces while carrying out decentralization,

.....

44. a) Match the items in A with those in B correctly.

**Mineral**

Coral reefs

Copper

Phosphates

Soda ash

**Product**

used to make glasses.

used to make artificial fertilizers.

used to make cement

used to make bullets

Coral reefs.....

Copper.....

Phosphates.....

Soda ash.....

45. Study the map below and answer questions about it.

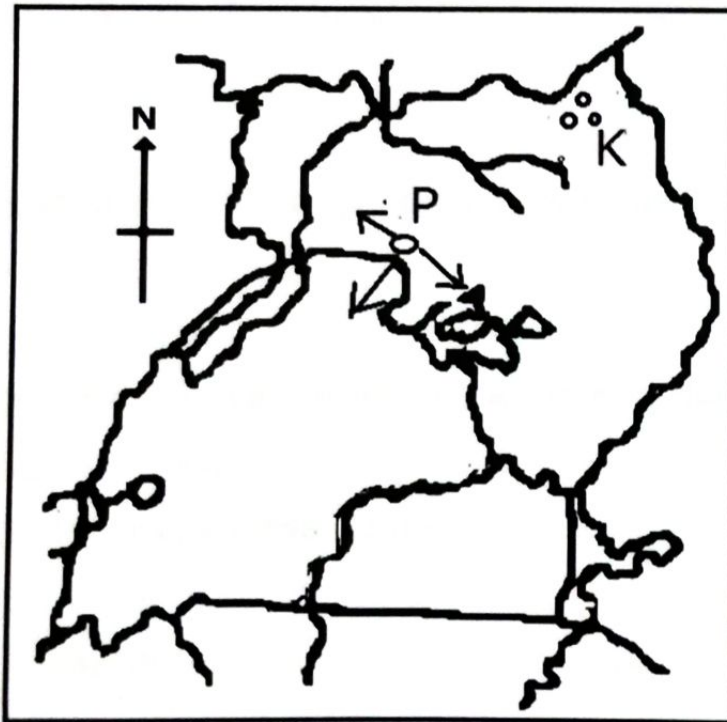

a) Name the Stone Age site marked K.

.....



b) How was place marked P useful to the Nilotics?

.....  
.....

c) Mention any one tribe under Highland Nilotes in Uganda.

.....

d) Use an arrow to indicate the direction used by the Hamites to enter Uganda.

46. a) Give any one reason why the government of Uganda is encouraging people to grow non-traditional cash crops.

.....  
.....

b) Mention any example of agro-based industry.

.....

c) How do farmers benefit from feeder roads?

.....  
.....

d) Give any one way people in rural areas support town dwellers.

.....  
.....

47. a) What role was played by the following during the construction of the Uganda railway?

(i) Sir George White House.....

.....

(ii) Sir Macdonald .....

.....

b) Give one reason Why the Uganda railway was constructed.

.....  
.....

c) Why did Africans refuse to provide labour during the construction of the Ugandan railway?

.....  
.....

**48.** a) Who was the eared of GEACO in East Africa?

.....

b) Give any one reason why chartered companies were formed in East Africa.

.....  
.....

c) Mention any problem face by chartered companies in East Africa.

.....

d) How were missionaries helpful to chartered companies like IBEACo?

.....  
.....

**49.** a) State any one cause of child abused.

.....

b) Mention any one form of child abuse.

.....

c) Give any two effects of violating children's rights.

i).....

ii).....

50. Use the map below and answer questions that follow.

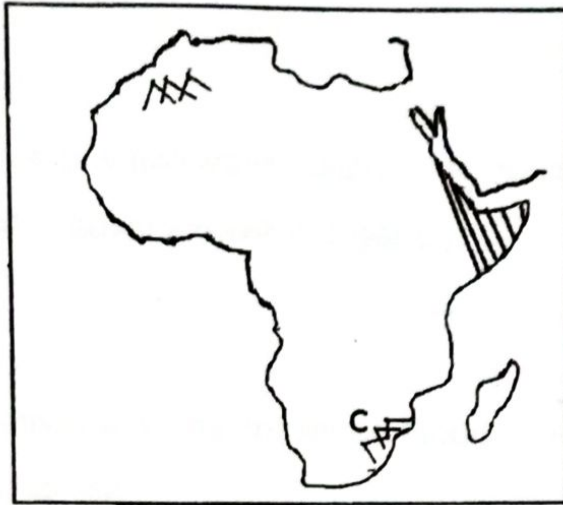

a) Name the landlocked country found in the shaded region.

.....

b) How did the above country become landlocked?

.....

.....

c) Name the relief feature marked C.

.....

d) How was the above feature formed?

.....

.....

**For questions 51- 555, answer Either Christianity OR Islamic But not both in the same number.**

**51. Either:**

a) State any two ways religious organizations have contributed to the economic development of Uganda:

i).....

ii).....

b) Mention any one challenge faced by religious organizations in Uganda.

.....

c) Name any one religious organization found in Uganda.

.....

**OR:**

a) Write UMEA in full

.....

b) Give any two importance of UMEA to Muslims in Uganda.

i).....

ii).....

c) State any one problem faced by UMEA.

.....

**52. Either: a) What is suffering?**

.....

.....

a) State any two forms of suffering

i).....

ii).....

b) Give any cause of suffering.

.....

OR

a) What is suffering?

.....

.....

c) State any two forms of suffering

i).....

ii).....

d) Give any cause of suffering.

.....

**53. Either:**

(a) Name the angel who brought good news about the birth of Jesus.

.....

(b) Why couldn't Mary believe that she could conceive?

.....

.....

(c) What important event was taking place at Bethlehem at the time Jesus was born?

.....

.....

(d) Why did Joseph and Mary have to flee to Egypt with baby Jesus just after this birth?

.....

**Or:**

(a) Which angel brought the first message to prophet Muhammad on Mt. Hiira?

.....

(b) Who became the leader of the Muslims after prophet Muhammad had died?

.....

(c) Mention the two mothers of Prophet Muhammad.

i) .....

ii) .....

**54. Either:**

(a) Why did Jesus Use parables in his teaching?

.....

(b) State the lessons that Christians learn from the following parables.

(i) Prodigal son .....

.....

(ii) Good Samaritan .....

.....

(iii) Lost sheep .....

.....

**Or:**

mention the first four pillars of Islam in their order.

(i).....

(ii) .....

(iii) .....

(iv) .....

**55. Either: Match items in list A with those in list B correctly.**

- | A          | B  |
|------------|--|
| Mt. Carmel | - Noah's ark rested                              |
| Mt. Olives | - Abraham tried to sacrifice Isaac               |
| Mt. Ararat | - Jesus Christ ascended to Heaven                |
| Mt. Moriah | - Elijah called fire to burn the Prophets of Bal |
- i) Mt. Carmel .....
- ii) Mt. Olives .....
- iii) Mt. Ararat .....
- iv) Mt. Moriah .....

**OR: Match items in list A with those in List B correctly.**

- | A      | B                  |
|--------|--------------------|
| Tauret | - Prophet Isa      |
| Zabur  | - Prophet Dauda    |
| Injir  | - Prophet Muhammad |
| Qur'an | -Prophet Musa      |
- i) Tauret .....
- ii) Zabur .....
- iii) Injir .....
- iv) Qur'an .....

**END**

## SECTION A: 40 MARKS

Answer **all** the questions in this section

Questions **1** to **20** carry two marks each

1. Workout:  $21 \times 3$

2. Write “Forty seven thousand, nine hundred eighty” in figures.

3. Given that:

Set  $P = \{\text{All factors of } 18\}$

Find  $n(P)$

4. Find the next two numbers in the sequence.

$$\frac{1}{2}, \frac{1}{4}, \frac{1}{8}, \frac{1}{16}, \underline{\hspace{2cm}}, \underline{\hspace{2cm}}$$



5. The number of pupils in a school reduced by 25%. If the original number of pupils was 1,800.

Find the current number of pupils in the school.

6. Express  $\frac{3}{8}$  as a decimal fraction.

7. Write the time shown on the watch in words.

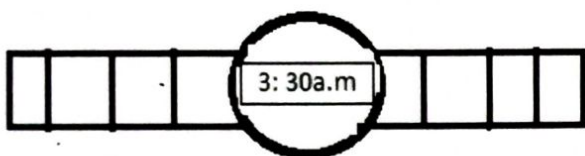

8. Bisect the obtuse angle on the diagram below.

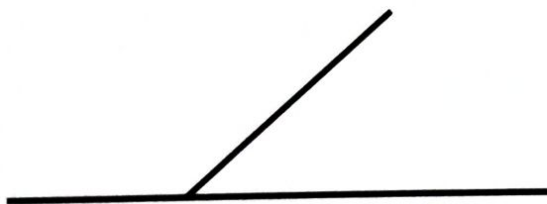

9. Using the diagram below, calculate the value of  $h$ .

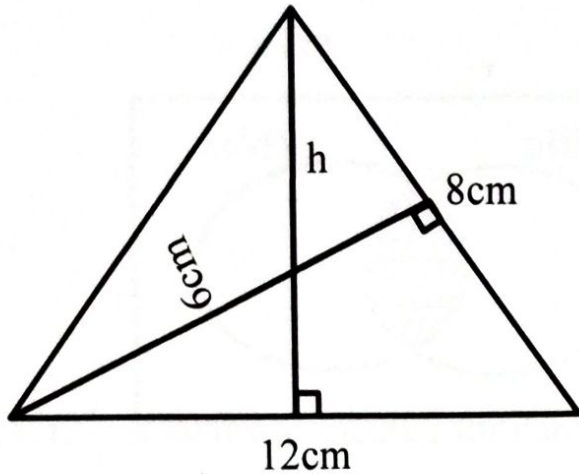

10. What is the multiplicative inverse of  $\frac{2}{5}$ ?

11. Given that 4 apples cost sh. 2,000. Find how many apples can one buy with sh. 6,000.

12. Given that  $Y = -4$ ,  $k=5$  and  $q=2$

Evaluate:  $k - yq^2$

13. Describe the unshaded part in the Venn diagram below.

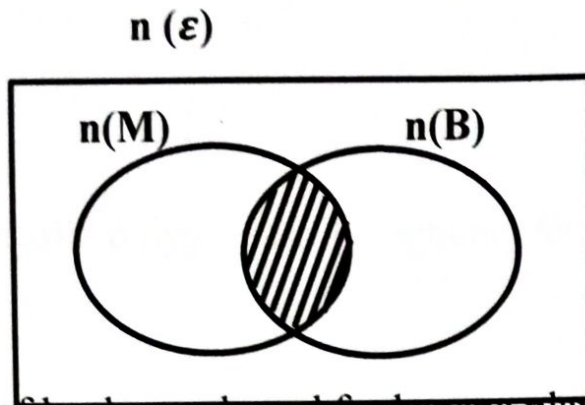

14. If  $\frac{2}{3}$  of land was cleared for banana plantation. And 120 hectares was left for crop growing. How many hectares were they altogether?

15. Prime factorise 36 and write your answer in exponents.

16. How many 250ml bottles of juice can one get from 2litres of the same juice?

17. Round off 12.649 to the nearest whole number.

18. A regular polygon has 12 right angles. How many sides has the polygon?

19. A driver left Kampala to Masaka with 8 passengers. When he reached Mpigi two passengers left the taxi and 4 passengers boarded from Lukaya. Find how many passengers reached Masaka.

20. Find the range of  $-2$ ,  $0$ ,  $-4$ , and  $-5$ .

## SECTION: B

Answer **all** questions in this section.

Marks for each part of the question are indicated in the brackets

21. Shirat went to the market with 3 -ten thousand shilling notes and bought the items as shown on the table.

a). Study it carefully and complete it.

Item	Unit cost	Quantity	Amount
Rice	_____	2kg	Sh. 7000
Beans	Sh.3,000	$2\frac{1}{2}$ kg	Sh. _____
Maize flour	Sh.2,500	_____	Sh. 7,500
Cooking Oil	Sh.12,000	_____ litres	Sh. 6,000
	TOTAL		_____

(5marks)

(b) Calculate how much Shirat paid for the items if she was given a discount of sh.8,000.

(1mark)

22. In a security training, bullets are shoot at an interval of 50 minutes and 75 minutes respectively.

a) After how many hours will they shoot together? (3marks)

b) If they last shoot together at 8:15pm, at what time before were they shoot together.

(2marks)

23. The Venn diagram below shows the number of tourists who visited Entebbe airport (E) and Uganda Museum (M). Use it to answer the questions that follow.

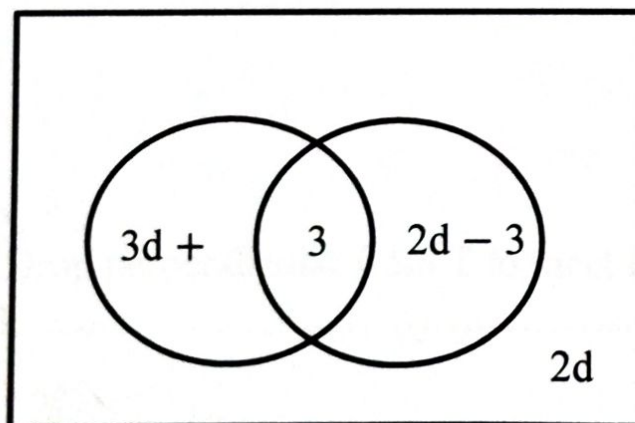

a) If 20 tourists did not visit Uganda Museum. Calculate the value of d.

(3marks)

b) Find the number of tourists who visited the two places. (2marks)

24. a) Using a pair of compasses, a ruler, a sharp pencil. Construct a triangle. EHT such that  $\overline{HE} = 8\text{cm}$ ,  $\angle HET = 60^\circ$  and  $\angle EHT = 30^\circ$  (4marks)

b) Drop perpendicular from T to meet HE at B. Measure TB..... (1mark)

25. Barbra, Rose, Gorreth and Merisha are pupils of P.7 whose average weight is 47kg. Merisha weighs 52kg and she is as heavy as Barbra. Gorreth is 4kg less than Barbra. Find Rose's weight. (5marks)

26. Study the number line below carefully and use it to answer the questions below.

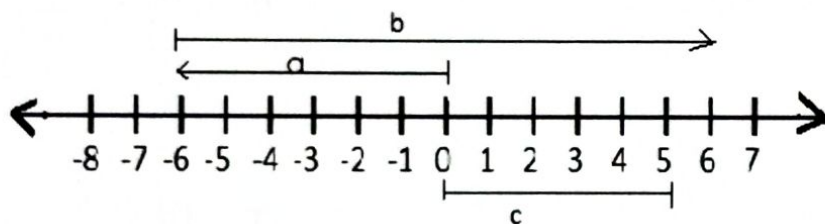

a) Write the integers for the arrows shown.

(1mark each)

a. \_\_\_\_\_ b \_\_\_\_\_

c \_\_\_\_\_

b) Write down the mathematical statement using the number line above.

(2marks)



27. Given that line AB is parallel to line CD Angle PTS=65° as shown on the diagram below.

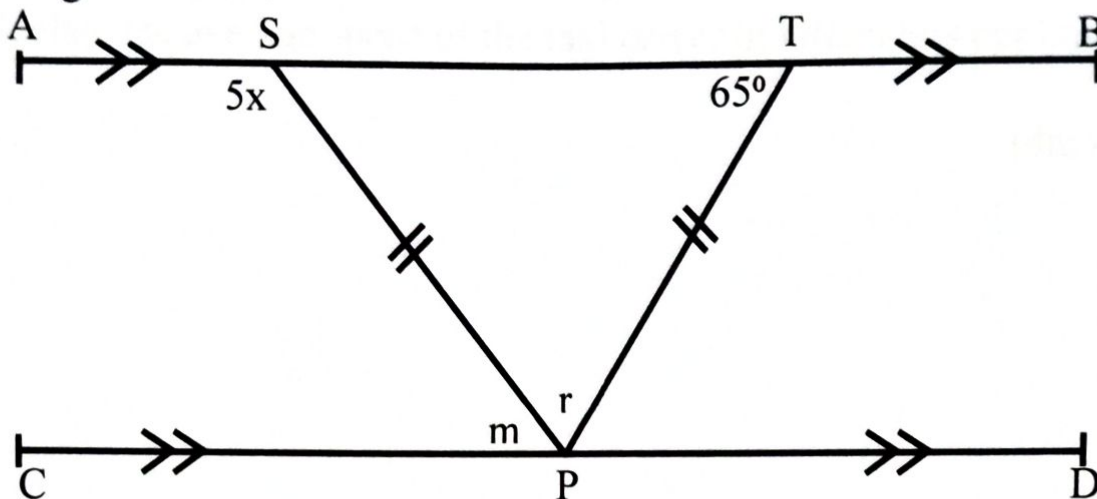

Find the value of:

i)  $x$  (2 marks)

ii)  $r$  (2 marks)

iii)  $m$  (1 mark)

28. A taxi driver leaves station Masaka at 9:45am and reaches Kampala station at 2:15pm. The distance between the two stations is 180km. Calculate the average speed of the taxi driver in kilometers per hour.

(4marks)

29. The diagram below shows a rectangular tank a farmer uses to collect his milk from the cows.

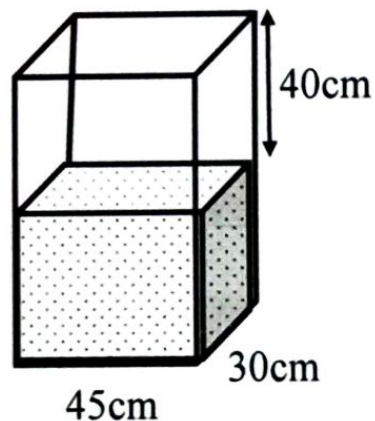

- a) If the tank now is  $\frac{1}{3}$  full of milk. Find the height of the full tank.

(2marks)

b) How many litres of milk are in the tank now?

(3marks)

30. Workout:

a)  $\frac{0.7-0.34}{0.2 \times 0.3}$

(3marks)

b) Simplify:  $\frac{1}{4} + \frac{5}{8} \div \frac{1}{2}$

(2marks)

31. a) Solve for x:  $3(3x - 3) - 2(2x - 2) = 15$

(3marks)

b) Given that the height of Peter is five times that of Mary. If the difference of their heights is 20cm.

Find Mary's height.

(2marks)

32. The graph below shows the number of pupils who were not immunized against COVID-19 in a certain school recorded from five classes with equal number of pupils of 140 in each class.

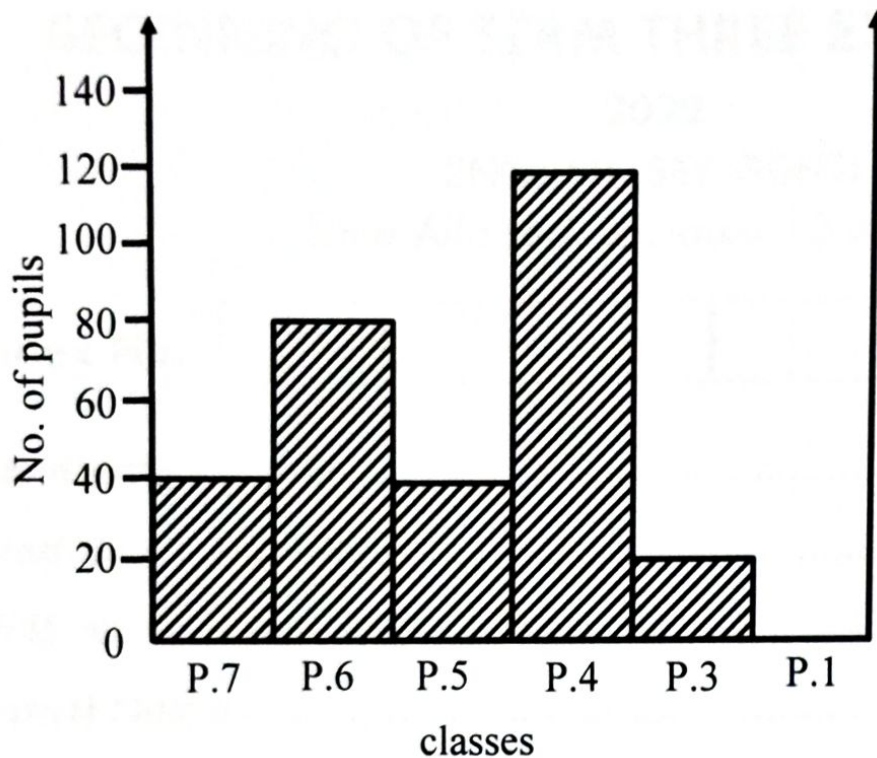

- a) In which class was the highest number of pupils immunized?

(1mark)

- b) Find how many pupils were immunized in P.4

(2marks)

- c) Find the total number of pupils who were not immunized in the 5 classes.

(2marks)

## SECTION: A

### Sub-section: 1

In each of the questions 1 to 5. Complete the sentences with the most suitable word.

1. The Teacher told us that the sun sets .....the west.
2. I found the ..... closed. So, I did not buy the meat I want.
3. By the .....he arrived. We had eaten supper.
4. He drove so ..... that he caused accidents.
5. May I have some soup, .....?

In each of the questions 6 to 15, use the correct form of word given in brackets to complete the sentences.

6. Dan is the .....boy in our class. (smart)
7. The chairperson's decision to send out one of the opposers sparked hot  
..... (argue).
8. If Ivan had money he ..... travel up-country. (will)
9. The Primary Four Learners Look forward to ..... the headteacher.  
(meet)
10. Our matron speaks French ..... (fluent)
11. The wasps ..... the boys who were stealing the old  
man's mangoes. (sting)
12. Only one ..... turned up for the interviews. (apply)
13. Mary's mother ..... her to work hard in everything she does.  
(courage)
14. It was such a .....that I ordered more. (taste)
15. A friend of .....celebrated his ninth birthday  
recently. (me)

In questions 16 and 17, rearrange the given words in alphabetical order.

16. bath, soap, basin, sponge

.....  
.....

17. poem, poetry, poetic, poet

.....  
.....

In questions 18 and 19, use each of the words in a sentence to show that you know the difference in their meaning.

18. feel:

.....  
.....

19. fill:

.....  
.....

In questions 20 to 22, rewrite the sentences giving a single word for the underlined group of words.

20. My dad's bulls and cows were struck by lightning last week

.....  
.....

21. Peter moved his car quickly in order to reach his work place in time.

.....  
.....

22. He all of a sudden died due to heart failure.

.....  
.....

In questions 23 and 24, write the short forms of the given words.

- 23. I had: .....
- 24. Government: .....

In questions 25 and 26, rewrite the sentences giving the opposite form of the underlined words.

- 25. My friend's condition is worse than it was in the morning.  
.....  
.....

- 26. Very few pupils passed the test.  
.....  
.....

In questions 27 and 28, write the plural form of the given words.

- 27. county: .....
- 28. lady's shoe .....

In questions 29 and 30, rearrange the given words to form meaningful sentences.

- 29. advisable to talk Is it while eating?  
.....  
.....

- 30. newspapers reads Jane rarely.  
.....  
.....



## Subsection II

*In each of the questions 31 to 50. Rewrite the following sentences as instructed in the brackets.*

31. The tourist will go to the zoo. It will be next week.

(Rewrite using:.....be going.....)

.....  
.....

32. Mr. Nkusi has flown to London I talked to him a few hours ago.

(Rewrite using: ..... whom.....)

.....  
.....

33. What is the cost of a new pair of scissors?

(Rewrite beginning: How much.....)

.....  
.....

34. Toka has not cleaned the kennel. Stamina has not cleaned the kennel  
(Join as one sentence using: ..... And neither.....)

.....  
.....

35. It was not necessary for the maid to drink the baby's milk.

(Rewrite using: .... needn't....)

.....  
.....

36. Unless the tailor uses the razorblade carefully, it will hurt her.

(Rewrite using: .....or else.....)

.....  
.....

37. This luggage said the conductor is very heavy.

(Punctuate the sentence correctly.)

.....  
.....

38. I am different from my friend. (Rewrite ending: ..... different)

.....  
.....

39. Our nephew bought a blanket made of wool. It was large. It was new.

(Rewrite as one sentence without using: 'who', 'that', 'which' or 'and')

.....  
.....

40. Makenke got lost although she had a map.

(Rewrite the sentence using: .....despite.....)

.....  
.....

41. I stole your pencil; you should forgive me.

(Join as one sentence beginning: Please.... for...)

.....  
.....

42. Pato and Rabinho are equally smart.

(Rewrite using: .....as.....as.....)

.....  
.....

43. I am more interested in digging than in fetching water.

(Rewrite using: ..... would....rather.....than.....)

.....  
.....

**44.** That vendor sells clothes. He also runs a dairy.

(Join as one sentence using: .... not only...)

.....  
.....

**45.** If the residents worked together, they would develop their community.

(Rewrite using: .....would have.....)

.....  
.....

**46.** Deba has arrived at the polling station late.

(Rewrite using:.....reached.....)

.....  
.....

**47.** Wanda organized hie bedroom immediately he woke up.

(Rewrite beginning: No sooner.....)

.....  
.....

**48.** Our class teacher advises daily. He wants us to grow responsibly.

(Rewrite using: ....so that....)

.....  
.....

**49.** The journalist is editing the article.

(Rewrite beginning: The article.....)

.....  
.....

**50.** Garbage collection will improve. We have a new track to collect it.

(Rewrite using: ..... Since.....)

.....  
.....

## SECTION: B

51. Read the passage below carefully and then answer in full sentences.

The questions that follow.

Napaku is a twelve-year-old girl. She goes to Nzoyiya Primary School in Masaka District. Napaku is a careless girl and that is her problem. She does not complete one activity at a time.

Before she completes washing utensils, you find her playing with friends and then later write her homework. She realizes that she had not completed washing utensils after trying like seven other different activities.

It was just a day after Napaku's school had broken up for second term's holiday when a terrible accident occurred at home.

That Saturday, Napaku and everybody else in the family wake up very early to prepare for the day's work. As usual, Napaku was left home to do home chores which included: washing utensils, cleaning the courtyard as well as looking after siblings.

Soon after Napaku's parents left for work, Napaku started washing the dirty utensils. As she was washing, a glass slipped off her hands and it broke into pieces. She got a broom and swept away the broken pieces of glass. Before she successfully swept them away, friends from the neighborhood invited her to join them in their usual games.

At the peak of their games. They started chasing one another. As they were chasing Napaku. She ran towards her home and she accidentally stepped on the broken pieces of glass she had swept earlier.

Eventually, she started crying for help. Her friends thought that she was tricking them to leave her.

'I warned you to always complete one activity at a time see what has happened to you'. Napaku's mother said as she was trying the wound with a clean cloth.

Napaku was taken to Bulamu Clinic for treatment. As she healed, she promised never to play carelessly.

(a) How old is Napaku?

.....  
.....

(b) What is Napaku's problem?

.....  
.....

(c) On which day of the week did learner in Napaku's school break up for second term's holiday?

.....  
.....

(d) According to the passage, why did all people in Napaku's home wake up early on one Saturday?

.....  
.....

(e) What did Napaku do when she was left home?

.....  
.....

(f) What got broken when Napaku was washing?

.....  
.....

(g) Who invited Napaku for a game?

.....  
.....

(h) Write a word or group of words to mean the same as the underlined words in the passage.

i) different .....

ii) invited .....

(i) Suggest a suitable title for the passage.

.....

52. Read the poem below carefully and then answer, in full sentences. The questions that follow.

I acquired a name,  
Right after my parents perished.  
How I wish thy never went to Nyendo.  
Intending to attend my uncle's wedding ceremony.

Sad news reached us that afternoon,  
Informing us my parents' demise,  
It was a speeding global bus,  
That lost control and at once crashed their Benz car.

Sorrow is my daily feast now,  
As my aunt torment me,  
Whipping me just for light mistakes,  
Making my like regrettable.  
I can endure most violent acts,  
But the denial of foo hurts,  
My body looks bony now,  
Though a healthy body I had.

**Questions:**

(a) When was the writer given the name?

.....  
.....

(b) Why had the writer's parents gone to Nyendo?

.....  
.....

(c) What was the sad news about, according to stanza two?

.....  
.....

(d) At what time of the day did the writer's parents die?

.....  
.....

(e) How does the writer's aunt torment the writer?

.....  
.....

(f) Is the writer denied food?

.....  
.....

(g) How many stanzas are in the poem?

.....  
.....

(h) Who do you think wrote the poem?

.....  
.....

(i) Write a word or group of words similar in meaning to the underlined words in the poem.

i) feast .....

ii) perished .....

**53. The sentences below are in a wrong order. Rearrange them in correct order to form a meaningful story about OUR JOURNEY TO MULAGO HOSPITAL.**

- a. We started this journey at around 9:00am.
- b. My mother decided to ask our neighbour to direct us.
- c. Two weeks ago, my mother and I wanted to go to Mulagu Hospital.
- d. From home to the main road, we just walked.
- e. Mother thanked the neighbour for his advice.
- f. The neighbour told us to first board up to Nateete Park.
- g. Unfortunately, we did not know where Mulago is found in Kampala.
- h. It is from Nateete Park that you can board straight to Mulago Hospital.
- i. After thanking him, we immediately started to prepare for the journey.
- j. At the main road, we waited for about 10miutes before we got a taxi to Nateete park

.....

.....

.....

.....

.....

.....

.....

.....

.....

.....

.....

.....

.....

.....

.....

.....

.....

.....

.....

.....

.....

.....

.....



54. The information below was found pinned to the notice board of Christ the King School, Kaliro on 03/03/2022. Study it carefully and in full sentences answer the questions that follow.

<b>ELECTION OF PREFECTS!</b>	<b>ELECTION OF PREFECTS!</b>
<b>All the students are hereby informed that there will be election of school prefects for 2022.</b>	
<b>Date:</b>	<b>05/03/2022.</b>
<b>Time:</b>	<b>9:00a.m. – 4:00p.m.</b>
<b>Posts:</b>	<b>1. Head prefect</b>
	<b>2. Sanitary prefect</b>
	<b>3. Games and Sports prefect</b>
	<b>4. Welfare prefect</b>
<b>Note: You are informed that no campaigns will be allowed on the Election Day, and if found, the candidate will be disqualified.</b>	
<b>OLIMBA NAAWE</b>	
<b>CHAIRMAN ELECTORAL COMMITTEE</b>	

a) What is the notice about?

.....

.....

b) When was this information pinned to the notice board?

.....  
.....

c) Where was this notice pinned?

.....  
.....

d) To whom was this information addressed?

.....  
.....

e) How many posts were indicated in the notice?

.....  
.....

f) What do you think happened to the candidate who was found campaigning on the election day?

.....  
.....

g) How long did the elections last that day?

.....  
.....

h) On which date did the pupils in this school elect their prefects?

.....  
.....

i) For which year were the elected prefects?

.....  
.....

j) Who wrote this information?

.....  
.....

55. Imagine you have just completed your Primary Leaving Examinations from Day Breeze Academy. Po box 80, Isingiro. Using that address, write a letter to your parents thanking them for providing you with all the school requirements throughout your primary level. Promise them that you will not let them down when you join secondary.

.....

.....

.....

.....

.....

.....

.....

.....

.....

.....

.....

.....

.....

.....

.....

.....

.....

.....

.....

.....

.....

**END**

**SECTION: A**

1. Name one Vulnerable group of people.

.....  
.....

2. State one effect of plastics to the soil.

.....  
.....

3. Give one way of caring for a human reproductive organ.

.....  
.....

4. Give any one way in which plants can be harmful to people.

.....  
.....

5. If a torch uses 2 pairs of dry cells. Workout the total voltage used by that torch.

6. Give any one chemical change in living things.

.....  
.....

7. How can the spread of COVID-19 be prevented at school?

.....  
.....

8. How do bees benefit plants?

.....  
.....

The diagram below shows a tool used on a dairy farm. Use it to answer question 8

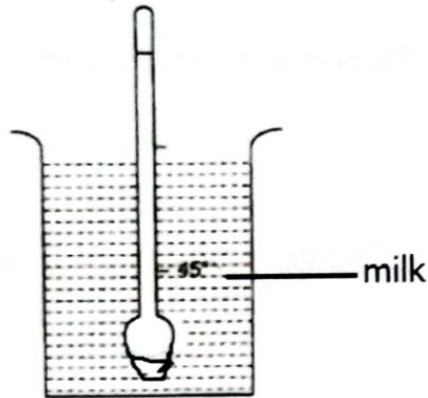

9. Give one reason why the above tool has sunk in the milk.

.....  
.....

10. Write down the first of the 4Fs.

.....  
.....

11. In which way are muscles important in the body?

.....  
.....

12. Name any one edible fungus.

.....  
.....

13. Give one way of caring for drums as musical instruments

.....  
.....

14. State any one characteristic of image formed by plane mirrors.

.....  
.....

15. Give one reason why bees swarm.

.....  
.....

16. How can incest be controlled at home?

.....  
.....

17. When does a land breeze take place?

.....  
.....

The diagram below is of a frying pan. Use it to answer question 18.

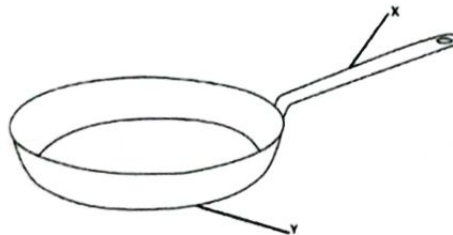

18. Name the metal used to make part Y

.....  
.....

19. Why do some farmers prefer keeping local breeds of cattle to exotic ones?

.....  
.....

**20. Why are traffic lights put on busy roads?**

.....  
.....

**21. Give the role of the gall bladder in the digestive system.**

.....  
.....

**22. Give way of preventing drug poisoning at home.**

.....  
.....

**23. Of what importance are trees planted in the compound?**

.....  
.....

**24. Which gas occupies the least percentage in the atmosphere?**

.....  
.....

**25. Give one activity which involves the use of filtration at home.**

.....  
.....

**26. State one importance of family planning.**

.....  
.....

**27. Why is it not easy to castrate a male pig with a burdizza?**

.....  
.....

**28. Of what disadvantage is seed dispersal to a crop farmer?**

.....  
.....

29. What happens to lungs when breathing in?

.....  
.....

The diagram below shows an eye defect. Use it to answer question

28.

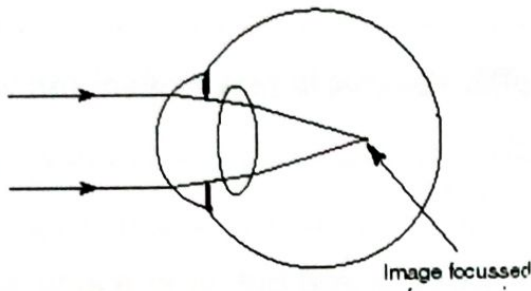

30. How is the above defect corrected?

.....  
.....

31. Name the deficiency disease caused due to shortage of vitamin C in body.

.....  
.....

32. Why should every boarding school have fire extinguishers?

.....  
.....

33. Name the addictive drug in tobacco.

.....  
.....

34. How are dry banana leaves useful in promoting hygiene of ordinary pit latrine?

.....  
.....



**35. Name any one type of vaccine.**

.....  
.....

**36. State any one importance of friction in our daily activities.**

.....  
.....

**37. How are insects and arachnids different in the way they breathe?**

.....  
.....

**38. In the space provided below, draw a body organ that filters blood.**

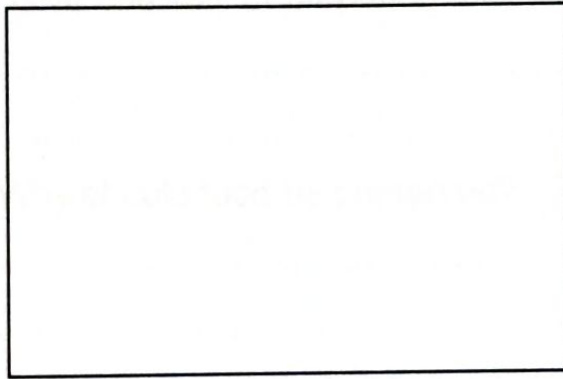

**39. Why should children suffering from measles be isolated?**

.....  
.....

**40. Which component of blood distributes heat in the body?**

.....  
.....

**SECTION: B**

**41.** a) Name any two non-living renewable resources.

i) .....

ii) .....

b) Give two ways of conserving non-renewable resources.

i) .....

ii) .....

**42.** a) State two reasons why food should be cooked.

i) .....

ii) .....

b) Give one way of preparing food.

.....  
.....

c) Why should food be preserved?

.....  
.....

**43.** a) Name one device that changes electric energy to sound energy.

.....  
.....

b) How is electricity useful at home?

.....  
.....

c) Give two reasons why electric wires covered with rubber.

i) .....

ii) .....

44. Below is a part of digestive system. Use it to answer the questions that follow.

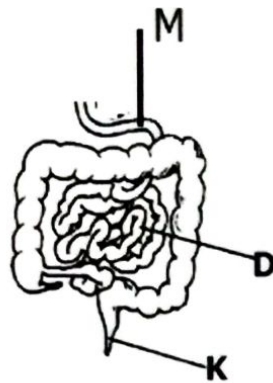

a) Name the part marked with letter M.

.....  
 .....

b) Which disease affects the part marked K?

.....  
 .....

c) Give two ways in which part "D" is able to carry out its function.

- i) .....
- ii) .....

45. a) State two ways in which landslides affect the environment

- i) .....
- ii) .....

b) Give one way of controlling each of the following natural changes in the environment.

- i) flood .....
- ii) drought.....

**46.** Match the vertebrates in list A with their groups in list B.

List A

bat

kite

turtle

newt

List B.

amphibian

reptile

mammal

bird

i) bat .....

ii) kite .....

iii) turtle .....

iv) newt .....

**47.** a) Name one tuber crop with erect stem.

.....  
.....

b) Give one way of harvesting tuber crops.

.....  
.....

c) How does sun drying preserve sliced cassava?

.....  
.....

d) Give one proper way of storing dried cassava safely.

.....  
.....

**48.** a) Give two causes of sickness at home

i) .....

ii) .....

b) State two ways of controlling common sickness at home.

- i) .....
- ii) .....

49. a) In which two ways do trees benefit crops growing together in the garden?

- i).....
- ii) .....

b) Mention two methods of harvesting trees that are friendly to the environment.

- i) .....
- ii) .....

50. a) Give an example of each of the following types of bones.

- i) long bone .....
- ii) irregular shaped bone .....

b) Which mineral salt is responsible for proper growth of bones?

.....  
.....

a) How is the human skeleton important to circulatory system?

.....  
.....

51. Below is a diagram showing first Aid equipment. Use it to answer the questions that follow.

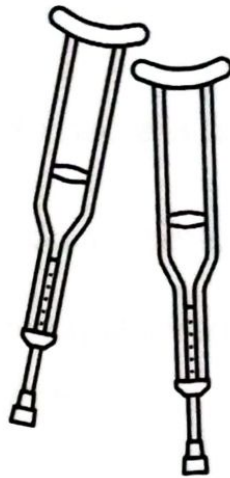

a) Identify the equipment shown above.

.....  
.....

b) How are the above equipment important to a casualty?

.....  
.....

c) Which injury requires the use of the above equipment?

.....  
.....

d) Of what importance is a First Aid to a casualty?

.....  
.....

52. a) State any two ways bacteria can be useful.

- i) .....
- ii) .....

b) In which two ways can bacteria be harmful to man?

- i) .....
- ii) .....

53. Below is a diagram showing children playing on a machine. Use it to answer questions that follow.

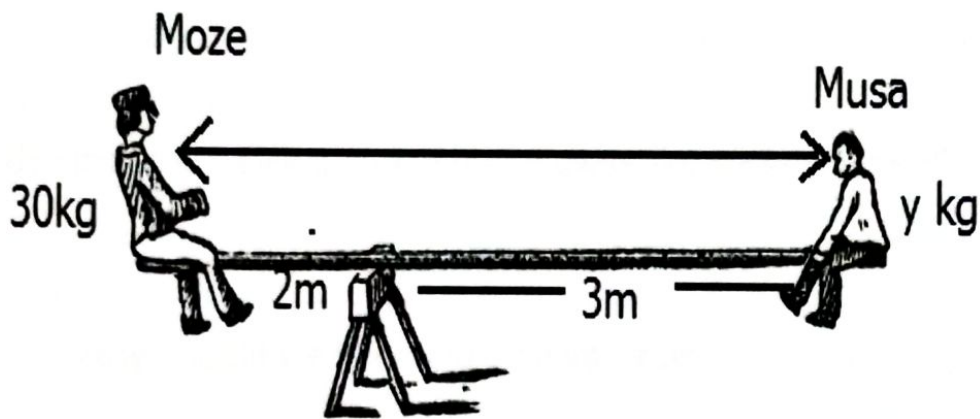

a) Which type of simple machine is shown above?

- .....
- .....

b) How far is Musa from Moze?

- .....
- .....

c) Calculate the weight of Musa

**54.** a) Give two exotic breeds of chicken kept for egg production.

i).....

ii) .....

b) Identify one factor that can lower egg production on a poultry farm.

.....  
.....

d) How does eating eggs control kwashiorkor in children?

.....  
.....

**55.** a) Why should we keep our bodies clean?

.....  
.....

b) Give one item used to clean the body

.....

c) State two activities we do to keep our bodies clean.

i) .....

ii) .....

**END**